

The Effects of Mountains on a Typhoon Vortex as Identified by Laboratory Experiments

*Hsien-Ping Pao**

The Catholic University of America, Washington, D.C. 20064

(Manuscript received 20 March 1976, in revised form 31 March 1976)

Abstract

In this study laboratory experiments were performed by introducing an essentially two-dimensional concentrated vortex which interacts with a two-dimensional elliptical barrier resembling the general shape of the island of Taiwan. Comparisons are made between the experimental results and field data. It is found that the general behavior and the accompanying surface flow patterns of a typhoon vortex, when interacting with the mountainous island of Taiwan, can be reasonably simulated in the laboratory. In the case of deflected flows, the typhoon vortex resembles a two-dimensional vortex past an equivalent two-dimensional mountain barrier and its pathline seems to be not sensitive to the typhoon strength. It is suggested that laboratory modeling may provide a reliable and effective way for predicting the movement of a typhoon vortex when it is in the vicinity of the island.

1. Introduction

Increasing awareness of and interests in the topographical effects on the atmospheric flows in recent years have led to numerous studies and investigations by many scientists around the world. It has also been recognized that mountain ranges do have strong interaction with and influence over typhoons and hurricanes. In certain cases the blocking and deflecting effects of the mountain barriers become very prominent. The mountain effect usually manifests itself in the form of floods and disasters for certain

areas. In the Pacific area, the mountain range of Taiwan stands out. It reaches a height well over 3,000 m above sea level. During every summer and early fall, the island of Taiwan has stood in the pathway of numerous violent typhoons in the last two decades for which observations have been quite extensive.

The problem of typhoon vortex passing over the central mountain range of Taiwan has been studied previously by Wang (1954, 1963), and Hsu and Wang (1960). Their works were mainly concerned with field data and their interpretations. More recent-

*On sabbatical leave; now visiting at the Institute of Physics, Academia Sinica, Taipei, and Institute of Naval Architecture, National Taiwan University, Taipei.

ly, in a series of reports Lin, Chu, Yu and others (1972, 1973, 1974) have analyzed field data of 102 typhoons covering a time span of 23 years (1949-71). Some statistical characteristics and wind field of typhoon vortex were intensively studied. Very recently, Brand and Blelloch (1974) have examined the field data of twenty-two typhoons (1960-72) regarding the changes in the characteristics of typhoons crossing the island of Taiwan. In these studies, it was evident that the high mountain on the island of Taiwan has indeed very strong interaction with and influence over the typhoon vortex.

Grossly speaking, typhoon or hurricane can be treated as a quasi-two-dimensional rotationally constrained fluid. Due to its high intensity of rotation and the flatness of its vortex, typhoon or hurricane has indeed a strong two-dimensional characters when interacting with a mountain range. This is essentially consistent with the Taylor-Proudman theorem of a rotating fluid (see for example Greenspan 1968).

In this preliminary study we performed experiments by introducing an essentially two-dimensional concentrated vortex which interacts with a two-dimensional elliptical barrier resembling the general shape of Taiwan island. Other shapes of barriers were also used. The basic objective of the present study is to find out whether the laboratory modeling can give a more definite answer to the following questions: If a mature typhoon is observed to be traveling in the general direction of approaching the island of Taiwan, (1) What is the general behavior of such a typhoon vortex when interacting with the mountain barrier? Any better way to predict the path line of the typhoon center? (2) Can the accompanying flow field be simulated in the laboratory?

(3) In the case of deflected flow, does the flow resemble a two-dimensional vortex past an equivalent two-dimensional barrier? (4) Is the vortex movement sensitive to the shape of the barrier? (5) How is the vortex movement affected by the approaching pathway of the vortex relative to the barrier?

From these preliminary experimental results and their comparisons with field data, we believe that satisfactory answers to the above listed questions have been found. We want to emphasize here that the laboratory modeling is certainly a valuable research tool in studying some atmospheric flow phenomena although it does have its limitations. For example, in this study, the typhoon vortex was treated as an essentially two-dimensional potential vortex with a viscous core; hence the detailed structure of the secondary flow in the typhoon vortex was not simulated in the laboratory. Thus, it by no means can replace the field observation or numerical modeling. Nevertheless, it is believed that the results from proper laboratory investigations are definitely complimentary to the actual field measurements; and that they will help to isolate certain important mechanisms and to untangle otherwise very complicated atmospheric flow phenomena, especially in the presence of mountain barriers.

2. Experimental Set-up and Procedures

The experiments were carried out in a Plexiglas flume 9.50 m long, 0.30 m deep, and 0.59 m wide. The flume was connected at both ends with inlet and outlet tanks, and a 5.0 h. p. pump was used for flow recirculation. Tracks and towing system were also available for towing the obstacles along the

flume. The experiments were performed in two stages.

(1) **Fixed vortex.** A copper tube of an outer diameter 3.4 cm with a roughened surface was used as a vortex generator. The tube was made to rotate about its axis at various speeds through a motor and gear system. The flow field thus generated is similar to a fixed vortex as shown in Fig. 1. Two-dimensional as well as three-dimensional barriers of various shapes were placed in the vicinity of the fixed vortex in order to study the flow patterns and the effects of the barrier.

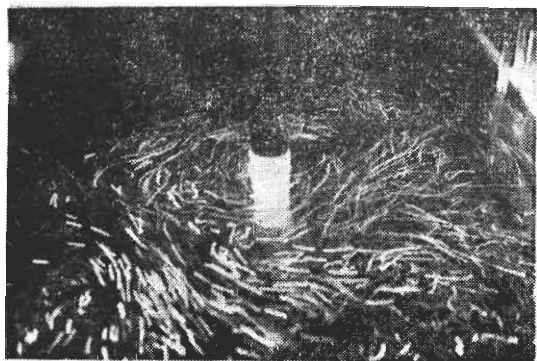

Figure 1. Streakline picture showing the flow pattern of the fixed vortex generated by a rotating copper tube. Experimental conditions: Rotating speed of the copper tube $\Omega=15.0$ rad/sec; outer diameter $2r_0=3.4$ cm; Rotational Reynolds No. $Re=\Omega r_0^2/\nu=4,300$.

(2) **Free vortex.** Various methods had been tried to create an essentially two-dimensional concentrated vortex in a channel filled with water of depth 25cm. Intuitively, the set-up for generating the fixed vortex can be modified so that the rotating copper tube or a circular rod connected to an electric hand-drill may be lifted out of the water after the vortex flow has been established, thus leaving a free vortex in the water. This technique, however, did not work. The turbulence created by the rotating tube and the disturbance caused by

lifting the tube were so strong that the remaining vortex was quickly dispersed and dissipated. It was found after many trials that a single two-dimensional concentrated vortex can effectively be created by suddenly moving an airfoil at an angle of attack. A vortex was shed instantly off the trailing edge of the airfoil (for more detailed discussions on this, see for example Batchelor 1967). It should be noted that another vortex of opposite sense was also shed as soon as the airfoil was brought from motion to rest. Therefore, the airfoil was kept moving for a considerable distance before it was brought gradually to rest; thus the second vortex was far apart from the first one and was also very much weakened and diffused.

A Cannon camera, with 45 mm lens was used to record the development of the flow field. A Cannon movie camera was also used for the case of free-vortex movement in order to record the continuous development of the flow field. The flow was made visible by a suspension of small (0.1~0.5mm) Pliolite S-5 beads which was illuminated by a horizontal sheath of light from two sides. Two light boxes were used for illumination; each one has horizontal openings at three levels, two inches apart, which permit observations of the flow pattern at any of these three levels. The Pliolite particles, having a specific gravity of about 1.05, sank slowly in a uniform cloud. To give particle streaks of a convenient length, and to show the flow pattern effectively, the shutter time was set at 1.0 sec. It was found that good quality streakline pictures can be obtained at f. 4.0~5.6 with a film speed of ASA 400 (Kodak Tri X Pan).

For the case of the fixed vortex the camera was mounted on a platform on top of the water channel. The motor was then



(a)

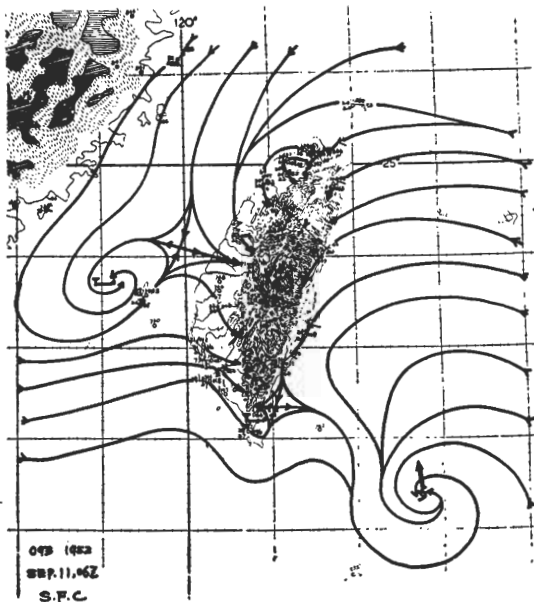

(b)

Figure 2. Comparison between experimental results and field data. (a) Streak-line picture showing the flow pattern of the fixed vortex in the presence of an elliptical barrier. Experimental conditions: $\Omega = 16.4$ rad/sec; $U = 0$; $t = 160$ sec; $r_0 = 1.7$ cm; $\beta = 45^\circ$; dimensions of the elliptical barrier: Diameter on the major axis $d_1 = 15.5$ cm, diameter on the minor axis $d_2 = 4.5$ cm; $Re = 4,740$. (b) Surface flow lines of typhoon 093, 1952 when encountering the island of Taiwan. Time: Sept. 11, 06Z; location of typhoon center: $122.7^\circ E$, $21.4^\circ N$; maximum wind speed = 50 kts.

started to rotate the copper tube and was kept at a constant rotating speed. The flow field was usually established in about ten minutes. Top view pictures were then taken successively at a rate of about four seconds per picture. Some specimen photographs from this series of experiments are shown in Fig. 1 to 5. Note that the rotating copper tube is sometimes hidden behind the elliptical barrier because of the angle of the camera. In this case various uniform flow speeds were used in the flume. For the case of the free vortex, to facilitate the picture taken and visual observations a large mirror was mounted on top of the flume, inclined at an angle of 45° . Therefore, the camera set in front of the inclined mirror can see a top view of the flow field in the mirror. A two-dimensional airfoil at an angle of attack of about 35° was set in a sudden motion, thus creating a concentrated vortex behind its trailing edge. The uniform flow in the flume acts as the steering flow for the vortex. Top view pictures were then taken successively. Some specimen photographs from this series of experiments are shown in Fig. 6 and 8.

3. Preliminary Experimental Results and Comparisons with Field Data

The experiments were performed in two stages. In the first stage, the vortex generated was bound to the rotating tube, hence it is termed as "fixed vortex". In the second stage of experiments, a free vortex shed from the trailing edge of an airfoil was created which is free to move in the flume. Many experimental runs have been made in the laboratory, however, only the representative results are presented here.

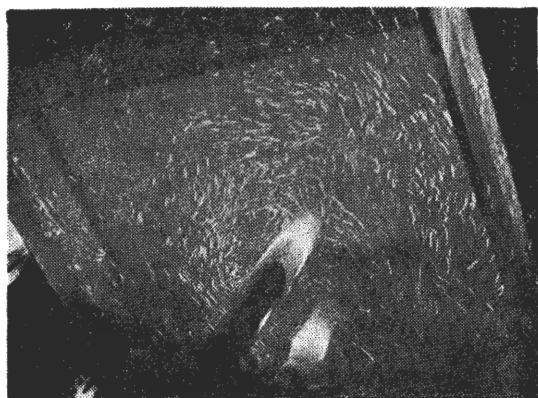

(a)

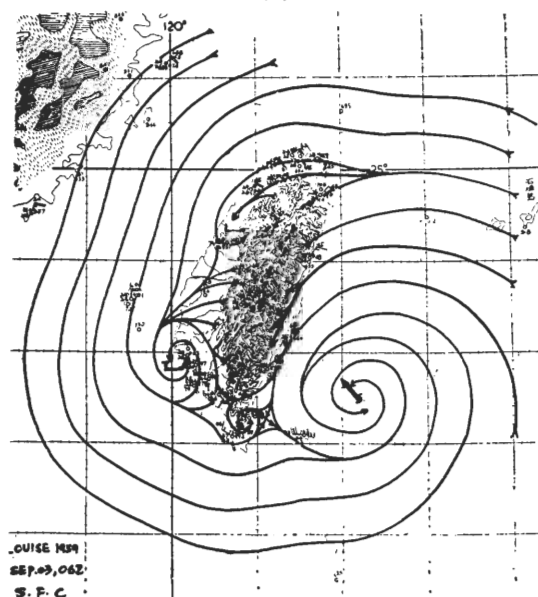

(b)

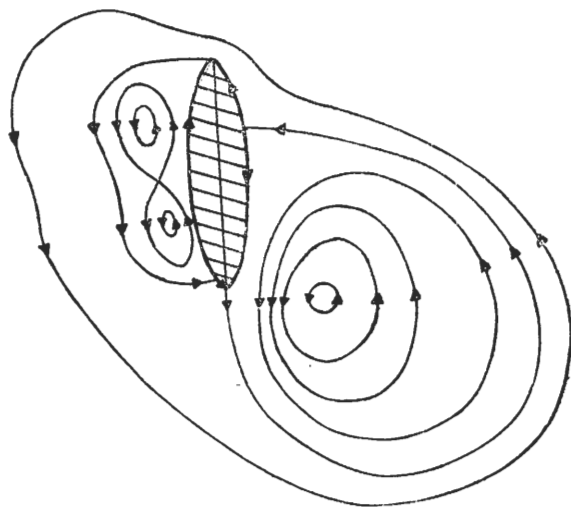

(c)

Figure 3. Comparison between experimental results and field data. (a) Streak-line picture. Same experimental conditions as in Fig. 2a except $t = 165$ sec. (b) Surface flow lines of typhoon Louise, 1959. Time: Sept. 03, 06Z; location: 122.2°E , 22.5°N ; maximum wind speed = 100 kts. (c) A sketch of streamlines for the flow field in (a).

(1) Fixed vortex

The purpose of this series of experiments is to study the flow patterns associated with a fixed vortex in the presence of a barrier. Fig. 2a, 3a and 4a show a time sequence of events of a single experimental run. The experimental conditions are: the rotating speed of the copper tube $\Omega = 16.4$ rad/sec, the basic uniform velocity $U = 0$, the angular position of the vortex relative to the major axis of the elliptical barrier $\beta = 45^{\circ}$. A sketch of the streamlines for the flow field is shown in Fig. 3c. It is noted that a series of pictures were taken only

after the rotating tube has been in rotation for more than 15 minutes and, therefore, the motion is presumably in a steady state. The time sequence for these pictures is $t = 160$ sec, 165 sec, and 200 sec, respectively, after a preset time which marks the beginning of a quasi-steady-state motion. As this series of pictures show that the motion actually never reaches a steady state. As the fluid of the fixed vortex flows around the elliptical barrier, flow separation occurs at the leading edge of the barrier. An induced eddy is formed and grows with time, as shown in Fig. 4a. As this eddy

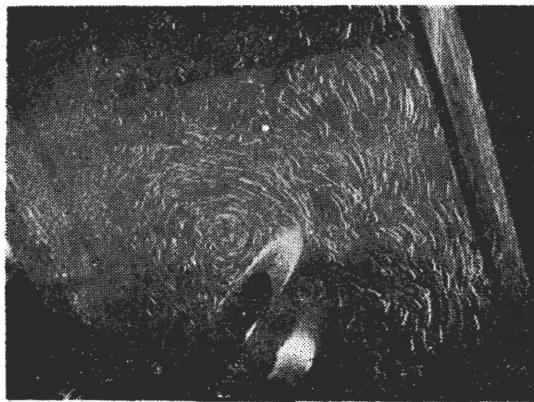

(a)

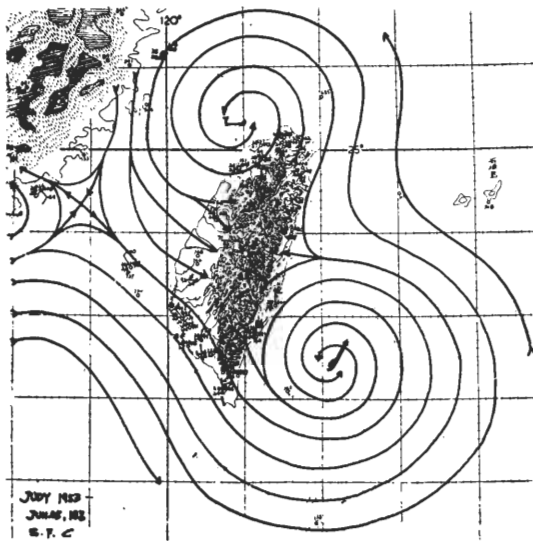

(b)

Figure 4. Comparison between experimental results and field data. (a) Streakline picture. Same experimental conditions as in Fig. 2a except $t = 200$ sec. (b) Surface flow lines of typhoon Judy, 1953. Time: June 05, 18 Z; location: 122.1°E , 22.4°N ; maximum wind speed = 60 kts.

grows, it tends to shed away from the leading edge. Due to the prevailing circulation of the fixed vortex, the first eddy is being carried toward the rear edge of the barriers while a second eddy is starting to form near the leading edge; consequently, the two eddies form a streamline of a figure "8" as shown in Fig. 2a, 3a and 3c.

The eddy near the leading edge has a tendency to grow in size while the rear eddy tends to diminish in size. As the leading eddy is growing, the rear eddy starts to shed away from the rear edge. This fact was confirmed in other pictures of the experiments (not shown here). When the rear eddy has been shed, the leading eddy has become full-grown and tends to be carried toward the rear, as shown in Fig. 4a. This completes a full cycle, before another eddy being formed at the leading edge. Therefore a single eddy or double eddies are formed in the lee side of a barrier as the vortex flow interacts with the barrier. For the purpose of comparison, surface flow lines for three typhoons (typhoon 093*, 1952; Louise, 1959; Judy, 1953) were analyzed and plotted in Fig. 2b, 3b and 4b. It is seen that the resemblance of the flow pattern between the experimental results and the field data is striking. Therefore, the dynamic lows in the field are now identified as the separation eddies which are shed away from the northern tip of the island. And the surface flow here is very similar to a two-dimensional vortex flow around an equivalent two-dimensional barrier. Figure 5a shows the streamline pattern for the case $\beta = 0$, where the vortex is located on the major axis of the elliptical barrier. The corresponding surface flow lines derived from the field data of typhoon Kate, 1962 are plotted in Fig. 5b. The agreement is again remarkable.

From the above series of experiments, it has been demonstrated that the surface flow patterns of a typhoon vortex when interacting with the mountainous island of Taiwan can be reasonably simulated in the laboratory. Three-dimensional flow field needs further investigation

* This is the tropical storm number assigned by the Weather Central, Chinese air Force.



(a)

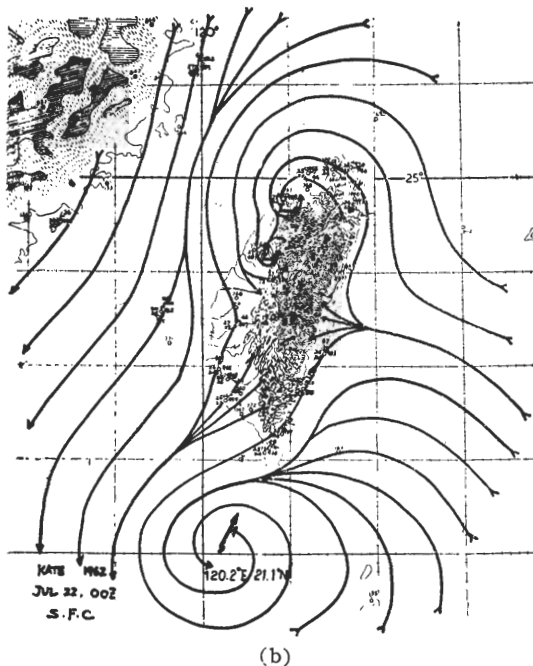

(b)

Figure 5. Comparison between experimental results and field (a) Streamline picture. Same experimental conditions as in Fig. 2a except $\beta=0^\circ$. (b) Surface flow lines of typhoon Kate, 1962. Time: July 22, 00Z; location: 120.2°E , 21.1°N ; maximum wind speed=70 kts.

(2) Free vortex

A series of experiments were also performed for the case of free vortex with various barrier angles and shapes. The top-view pictures shown in Fig. 6 are from a representative experiment for a free vortex approaching an elliptical barrier. Figure 6

shows the time development of the induced eddy at the tip of the barrier and the movement of the free vortex. The free vortex is generated in a stream of uniform flow with $U=1.9$ cmces/. In Fig. 6a, the free vortex is shown to be approaching the barrier from the right side of the picture at an angle of 45° to the major axis of the elliptical barrier. An eddy is being formed at the tip on the lee side of the barrier. The streamline pattern here has a striking resemblance to the surface flow lines of typhoon Judy (1953) shown in Fig. 4b. These pictures are selected from those taken in the same run. The time interval between successive pictures is about five sec. It is seen that the main vortex has a tendency to veer to the right as it approaches the barrier. As the main vortex is passing around the tip, the induced eddy is also drifting away from the barrier, as shown in Fig. 6c and 6d. In the meantime, the movement of the induced eddy is always under the influence of the main vortex. As the main vortex is moving downstream, it quickly overtakes the induced eddy. At this time, these two vortices behaves very much like a vortex pair with, of course, different strengths. In fact, at the position shown in Fig. 6f, the induced eddy tends to move in the upstream direction due to the induced motion derived from the main vortex. The path line of the center of the free vortex can accurately be determined by examining these time-elapsd photographs. Several representative path lines are now plotted as dotted lines in Fig. 7. Eight typhoon tracks are also plotted in the same figure as the mountain barrier interacts and deflects the typhoon vortex. It is seen that the agreement between the laboratory results and the field data is very good. In the case of typhoon Thelma

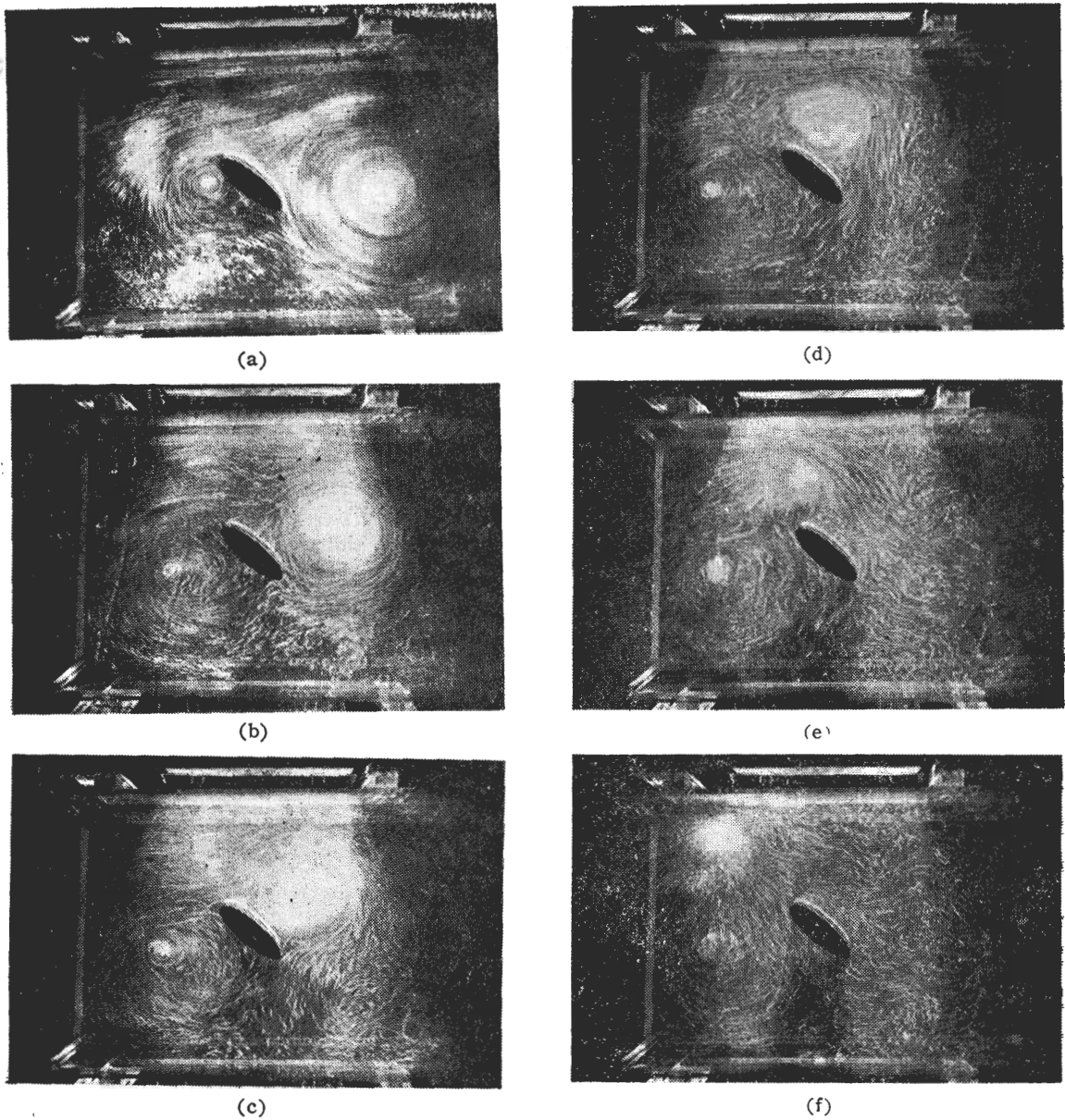

Figure 6. Laboratory experiment of a free vortex past an elliptical barrier. Angle of approach $\alpha=45^\circ$, $U=1.9$ cm/sec.

(1956), the field track practically coincides with that obtained from the laboratory. It is noted that the strengths of these free vortices in the experiments have not been determined and the strengths of these eight typhoons are also chosen arbitrarily. Hence, the fact, that the agreement is good

regardless of the strengths, seems to indicate that for deflected typhoons the path lines are somewhat not sensitive to the typhoon strengths. From Fig. 7, it is seen that the vortex movement is strongly affected by the approaching pathway of the vortex relative to the barrier. More detailed

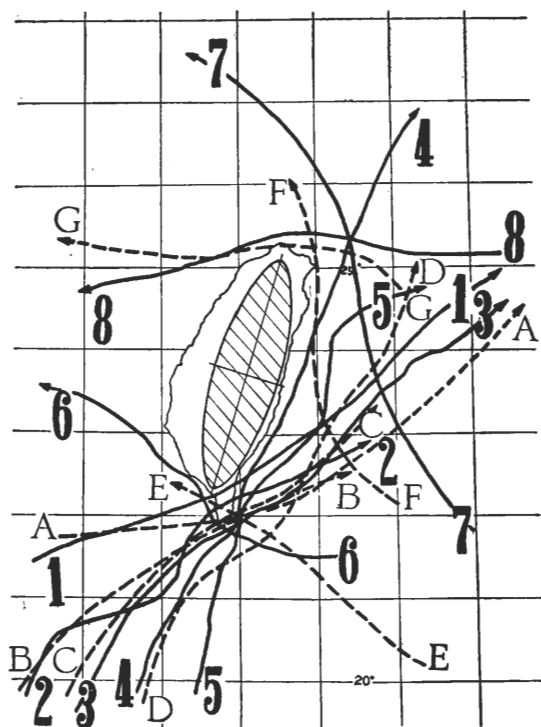

Figure 7. Comparison of eight typhoon tracks with the pathlines of a free vortex obtained from the experiments. The number of each typhoon track corresponds to the following typhoons: 1. Elsie, 15-17 Sept. 1966; 2. Babs, 8-9 Oct. 1959; 3. Thelma, 22-24 April 1956; 4. Kate, 21-23 July 1962; 5. Freda, 18-19 Nov. 1959; 6. Elsie, 13-14 July 1961; 7. Typhoon 084, 16-17 Aug. 1955; 8. Trix, 7-8 Aug. 1960.
 --- typhoon track; - - - experimental path line

and definitive conclusions have to await further investigations. It is also noted that three-dimensional barriers were also used for some runs, but it is still too early, for the time being, to make any significant statements.

One of the most interesting facts as mentioned in the previous section is the tendency for the main vortex to be veering to the right as it approaches a barrier. This is actually a well-known fact for the typhoon vortex (see, for example, Hsu and

Wang 1960, or Blelloch 1974). Initially, it was conjectured by this author that this is probably due to the "tip" effect of the island. In other words, the salient southern tip of the island of Taiwan was thought to be the controlling factor for the typhoon vortex to be veering to the right. This explanation was, however, quickly found to be untrue. This fact is easily tested in the laboratory by using a circular cylindrical barrier. Figure 8 shows the time-elapsd top-view pictures for a free vortex in the presence of a circular barrier. The basic uniform flow in the flume is set to zero. Therefore, the only primary motion is the free vortex itself. It is seen convincingly that the vortex moves around the circular barrier in such a way that it always stays on the right-hand side of the cylinder. Therefore, veering to the right is not a consequence of the tip effect of the island.

It is well known from the classical hydrodynamics that a single vortex in a fluid near a wall will acquire an induced velocity parallel to the wall (see, for example, Lamb 1932). In fact, if the fluid were inviscid, and hence did not separate, the point vortex in Fig 8 would be moving around the circular cylinder in a clockwise direction. Therefore, viscous effects and flow separation seem to be the only reasons for the real vortex to move in the opposite direction, i.e., counterclockwise. This calls for a careful analytical study in order to resolve this apparent discrepancy. The most tempting explanation here is probably that viscous effects and flow separation have induced a net circulation for a closed circuit around the cylinder without enclosing the point vortex; and the sense of this net circulation is the same as that of the free vortex itself. As a consequence, the vortex

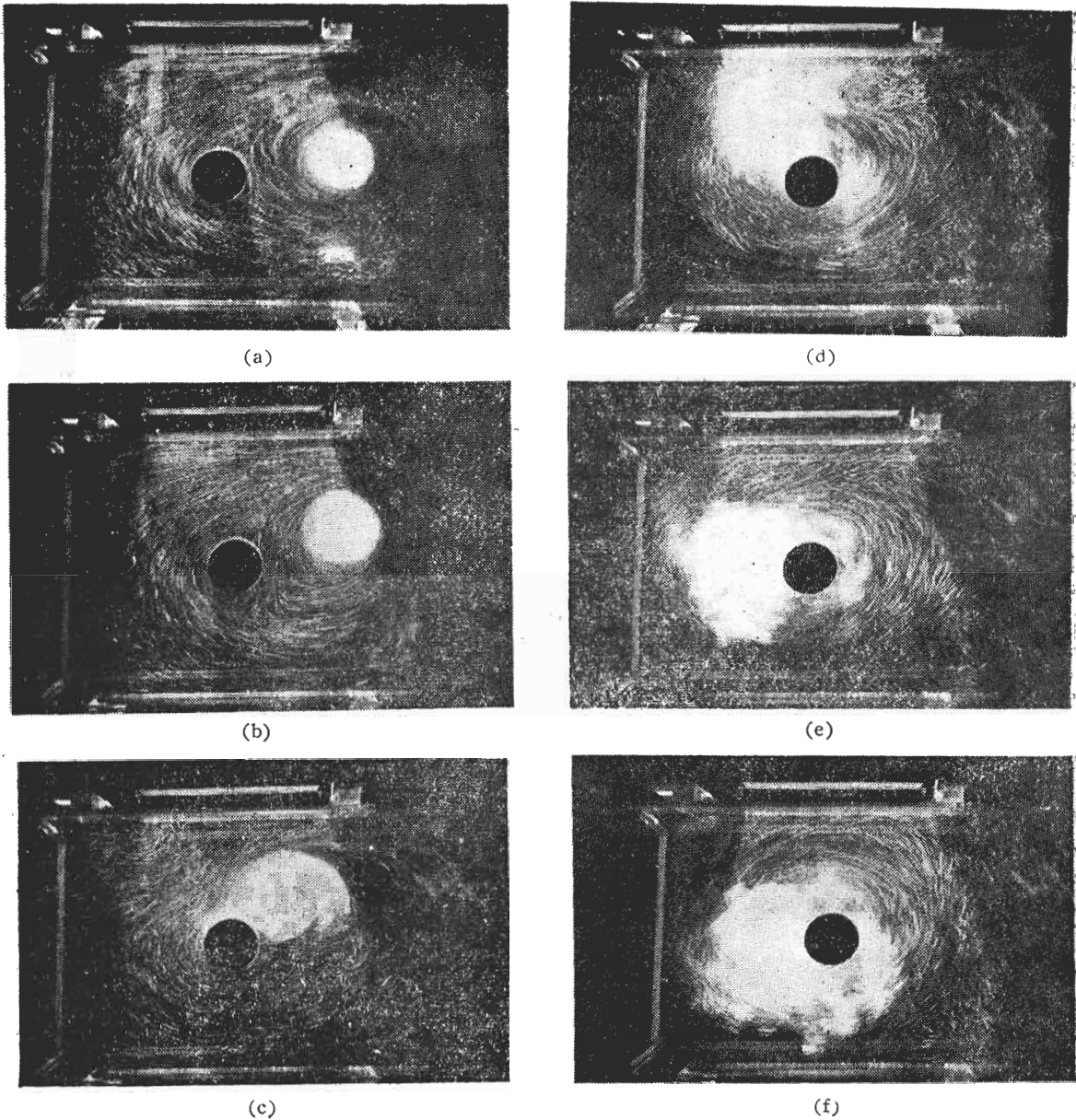

Figure 8. Laboratory experiment of a free vortex past a circular cylindrical barrier. $U=0$.

is steered around the cylinder in a counter-clockwise direction.

Finally, it is noted that for a free vortex in the presence of a circular barrier the induced eddy at the lee side of the barrier is very much weakened when comparing with that near the elliptical one.

Therefore, the tip or shape effect is indeed prominent as far as the strengths and sizes of the induced eddies are concerned.

4. Concluding Remarks

In the present laboratory study, several shortcomings are noted as far as the

simulation of the typhoon vortex is concerned.

First, the concentrated quasi-two-dimensional free vortex produced in the laboratory is purely mechanical, that is, the important effect of latent heat was not incorporated here. Thus, the free vortex, once created, is subject to decay as it moves along. Considerable amount of dissipation and weakening also occurs as it encounters the barrier. Therefore, we have essentially assumed that the typhoon vortex has already attained a mature strength and thus no further growth is occurring as it approaches the island of Taiwan. This, however, seems to be true for most of typhoons approaching Taiwan. Moreover, the average intensity of typhoons was indeed reduced substantially after they have crossed the island (Brand and Belloch 1974). Furthermore, many flow features, occurring during the interaction between the vortex and the barrier observed in the laboratory, seem to be not sensitive to the vortex intensity. Therefore, the effect of latent heat is perhaps of secondary importance in the present situation. The latent heat is, of course, of primary importance during the formative and growing stages of a typhoon. It is also of importance when studying the structure and maintenance of a mature typhoon (Yanai 1964).

Second, the detailed structure of the secondary flow in the typhoon vortex was not provided for in the laboratory.

Third, the aspect ratio of the vertical and horizontal dimensions of the free vortex in the laboratory is considerably different from those of the typhoon vortex. This is almost unavoidable for a laboratory modeling of this kind. The vertical dimension is always distorted. But a strong vortex does possess a strong

two-dimensional characteristic which is observed vividly in the experiment. Moreover, in the present study, only the case of the two-dimensional vortex interacting with a two-dimensional barrier is considered. Therefore the vertically distorted model is of no consequence here.

Forth, the Coriolis effect is neglected in the laboratory model.

In spite of these shortcomings in the laboratory model, the agreement between experimental results and the field data is very good. This strongly underlines an important fact that the present laboratory model has incorporated all essential dynamic factors in so far as the interaction of the typhoon vortex with the mountain barrier is concerned. Indeed, when the typhoon vortex approaches the island of Taiwan, the mechanical encounter between the vortex and the mountain barrier ought to be the sole dominant factor in the entire event. Therefore, the present laboratory model has provided a first-order solution to the typhoon movement in the immediate vicinity of the island. The effects of the latent heat, the detailed secondary flow in the typhoon vortex and the Coriolis force can be considered as of secondary importance.

With the above remarks, we now make the following tentative conclusions:

(1) It has been convincingly demonstrated that the general behavior and the accompanying surface flow patterns of a typhoon vortex when interacting with the mountainous island of Taiwan can be reasonably simulated in the laboratory.

(2) In the case of deflected flows, the typhoon vortex resembles a two-dimensional vortex past an equivalent two-dimensional mountain barrier.

(3) The vortex movement seems to be not sensitive to the shape of the barrier.

(4) For deflected typhoons the path lines seem to be somewhat insensitive to the typhoon strengths.

(5) The vortex movement is strongly affected by the approaching pathway of the vortex relative to the barrier.

(6) Laboratory modeling may provide a reliable and effective way for predicting the movement of a typhoon vortex when it is in the immediate vicinity of the island of Taiwan.

Acknowledgments: The author wishes to express his gratitude to Dr. Chun-Tsung Wang for his encouragement and hospitality while visiting the Institute of Physics, Academia Sinica, to Col. K. C. Chu and Col. Shih-Ting Wang for providing the analyzed typhoon data in Fig. 2, 3, 4 and 5, and for their valuable discussions, to Mr. Jin Jso for his assistance in the laboratory experiments. This work was supported by the Office of International Programs, National Science Foundation under Grant OIP 75-09275. Thanks are also due to the National Science Council of ROC for its partial support.

References

- Batchelor, G. K., 1967: *An Introduction to Fluid Mechanics*. London, Cambridge University Press.
- Brand, S., and J. W. Belloch, 1974: Changes in characteristics of typhoons crossing the island of Taiwan. *Mon. Wea. Rev.*, 102, 708-713.
- Greenspan, H. P., 1969: *The Theory of Rotating Fluids*, London, Cambridge University Press.
- Hsu, Y. C., and S. T. Wang, 1960: On the problem of prediction of typhoons in the vicinity of Taiwan. *Weather Forecast and Analysis*, Quarterly, No. 2, Weather Central, CAF. (in Chinese)
- Lamb, H., 1932: *Hydrodynamics*. New York, Dover.
- Lin, T. M., K. C. Chu, C. C. Yu, and Others, 1972, 1973 & 1974: On the wind force of typhoons affecting Taiwan. Research Reports of Weather Central, CAF, No. 004, No. 005, No. 006. (in Chinese)
- Wang, S. T., 1954: On typhoons passing over the central mountain of Taiwan. *Weather Analysis of China*, Monthly, Vol. 4, No. 10, Weather Central, CAF. (in Chinese)
- Wang, S. T., 1963: Topographical effect on typhoons moving along the central mountain of Taiwan. *Weather Forecasting and Analysis*, Quarterly, No. 14, Weather Central, CAF. (in Chinese)
- Yanai, M., 1964: Formation of tropical cyclones. *Reviews Geophys.*, 2, 367-414.

山脈對颱風影響的實驗研究

鮑 咸 平

美國天主教大學

摘 要

在這分報告裏，藉着一個與臺灣地形相似的二度橢圓障礙體和一個二度強渦流發生作用，以從事實驗研究。將實驗結果與氣象實際觀測數據比較，發現在實驗室中，可以合理地模擬颱風渦旋與臺灣島交互作用時的一般動態及其表面流態。在有偏流的狀況時，颱風渦旋頗類似一二度渦旋流經一二度山脈，而其路徑與渦旋的強度似乎並不關聯。這分研究顯示模型實驗似可提供一可靠且有效的方法來預測颱風在臺灣島附近的運動情形。